

Lovejoy Rosta Motorbases

Belt drives transmit the proper torque only if the belt tension is correct. Failure to adjust the tension leads to a loss of power, overheating of the belts, excessive wear of the pulleys, and eventual premature failure.

Applied and Lovejoy are pleased to present the ROSTA self-tensioning motorbase for all of your belt drive applications. The ROSTA motorbase continually tensions belts, compensates for belt stretch, dampens vibrations from the belt to the motor, and simplifies belt change outs. The motorbase utilizes an elastic element design, which has been tested and operated in the most demanding aggregate applications for more than 50 years.

Aggregate Industry Applications:

- Shaker Screens
- Crushers
- Dewatering Screens

Features/Benefits:

- ✓ **5 Times Longer Belt Life** – maintaining proper belt tension increases the life of your belts.
- ✓ **Quick Belt Change Outs** – unique design allows for belts to be changed in a matter of minutes.
- ✓ **Self-Adjusting and Maintenance Free** – once installed, the ROSTA motorbase will constantly maintain proper belt tension thus eliminating the need for costly and time consuming maintenance.
- ✓ **Longer Motor Life** – dampening belt vibrations increases life of motor shaft bearing.
- ✓ **Saves Money** – ROSTA motorbase reduces maintenance cost, and increases belt and motor life, which adds up to increased productivity.



To select the correct Rosta motorbase size:
1. Identify the NEMA Frame Size
2. Use the chart below

Type	Motor HP @1750 rpm	NEMA Frame Size	Weight (lbs.)
MB 50 x 160	7.5-10	213T & 215T	86
MB 50 x 200	15-20	254T & 256T	94
MB 50 x 270	25-30	284T & 286T	108
MB 50 x 400	40-50	324T & 326T	124
MB 50 x 500	60-75	364T & 365T	144
MB 70 x 400	100	404T	275
MB 70 x 550	125	405T	350
MB 70 x 550	150	444T	350
MB 50 x 650	200*	445T	425

*Not recommended in applications where the base has to lift the entire weight of the motor

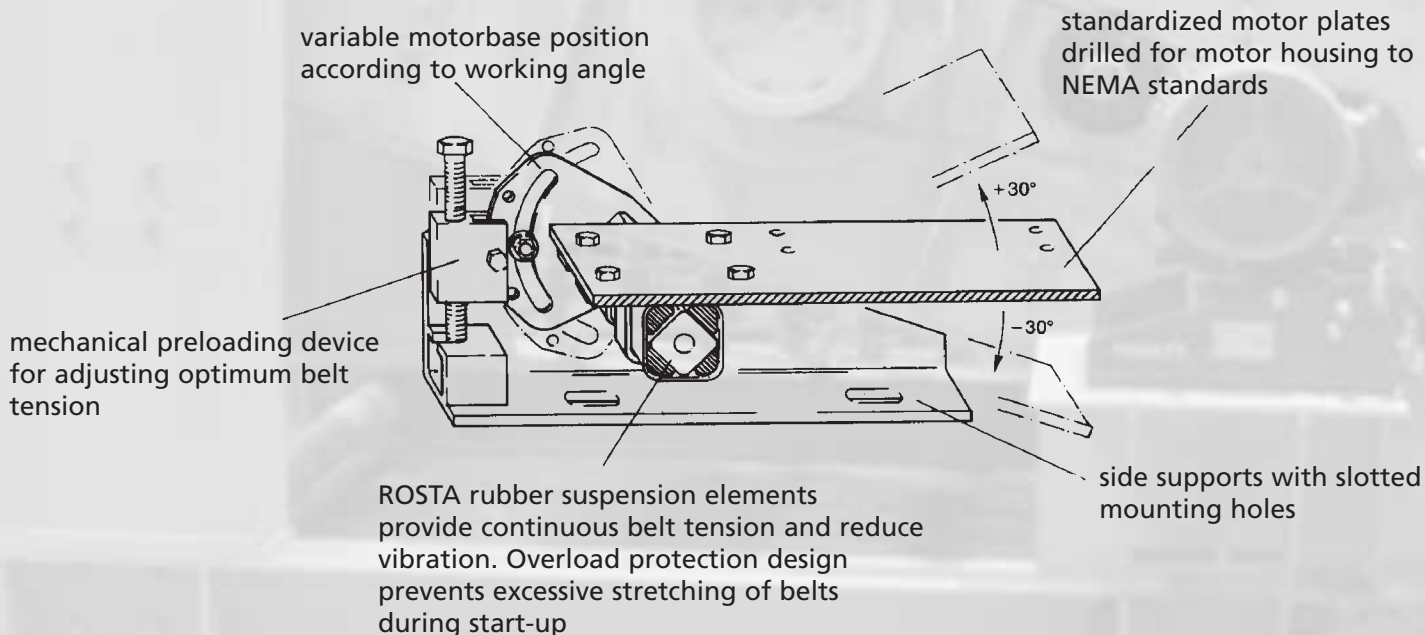

Contact Your Local Authorized Service Center
1-877-279-2799



Value Through Innovation

One Applied Plaza
 Cleveland, Ohio 44115-5000
 Toll Free Phone: 1-877-279-2799
 www.appliedindustrial.com